

C964 C962 C960 (110V) (240V)	P/N 36158	REV: F
DRAWN BY: X. SNYDER	DATE: 4/14/95	SHEET 1 OF 5

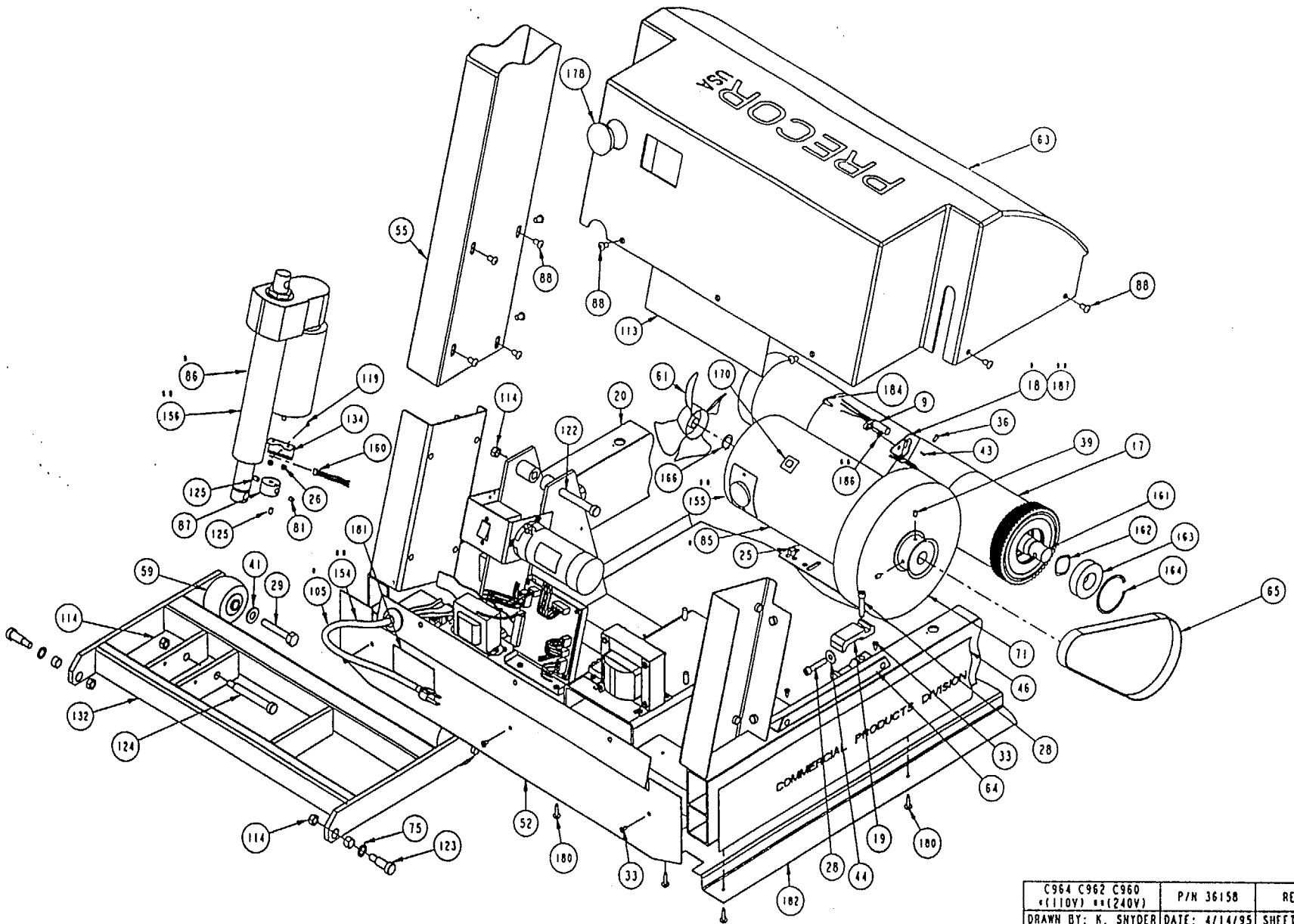

C964 C962 C960 *(110V) **(240V)	P/N 36158	REV: F
DRAWN BY: K. SNYDER	DATE: 4/14/95	SHEET 2 OF 5

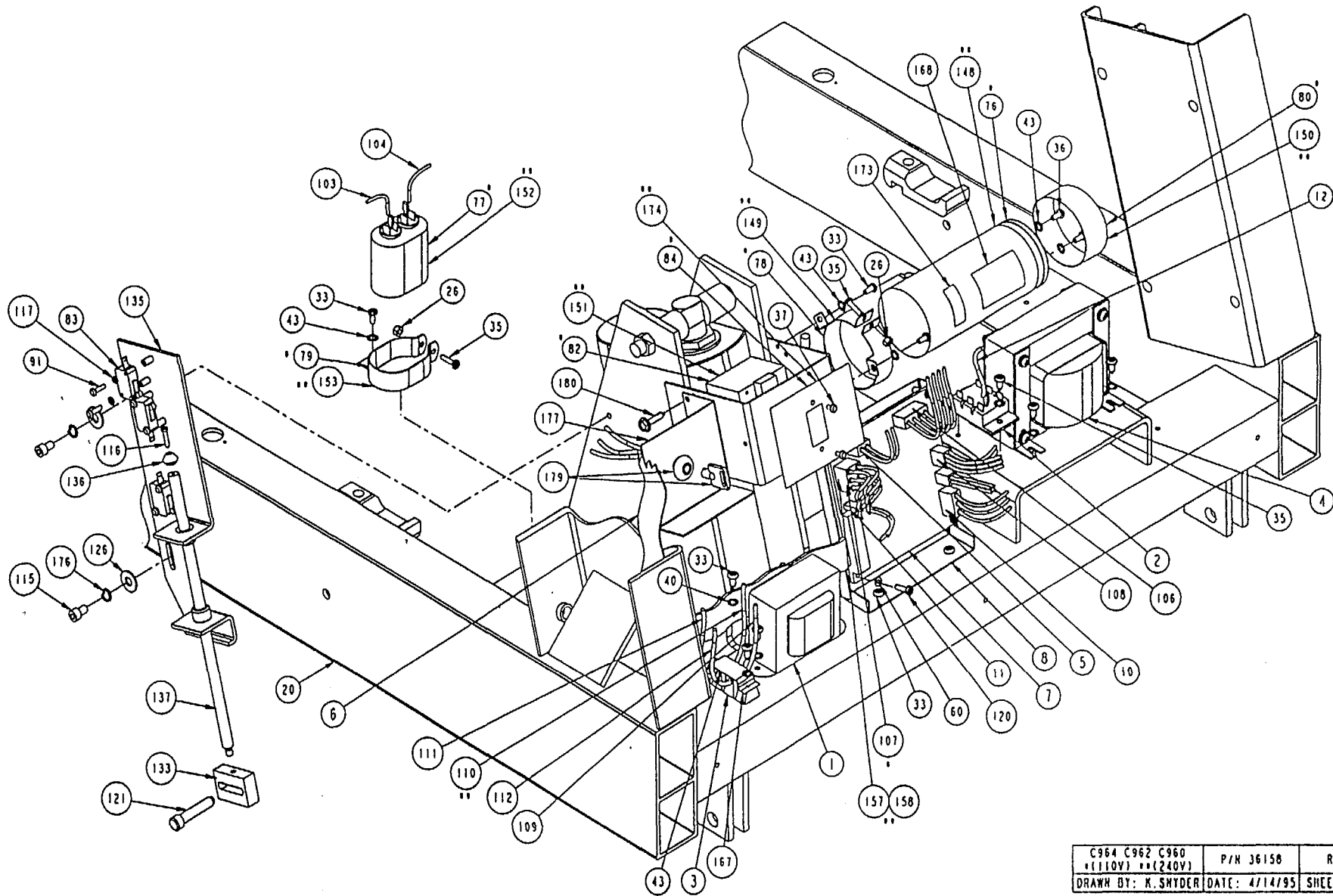

C964 C962 C960 *(110V) ***(240V)	P/N 36158	REV: F
DRAWN BY: K. SHYDER	DATE: 4/14/95	SHEET 3 OF 5

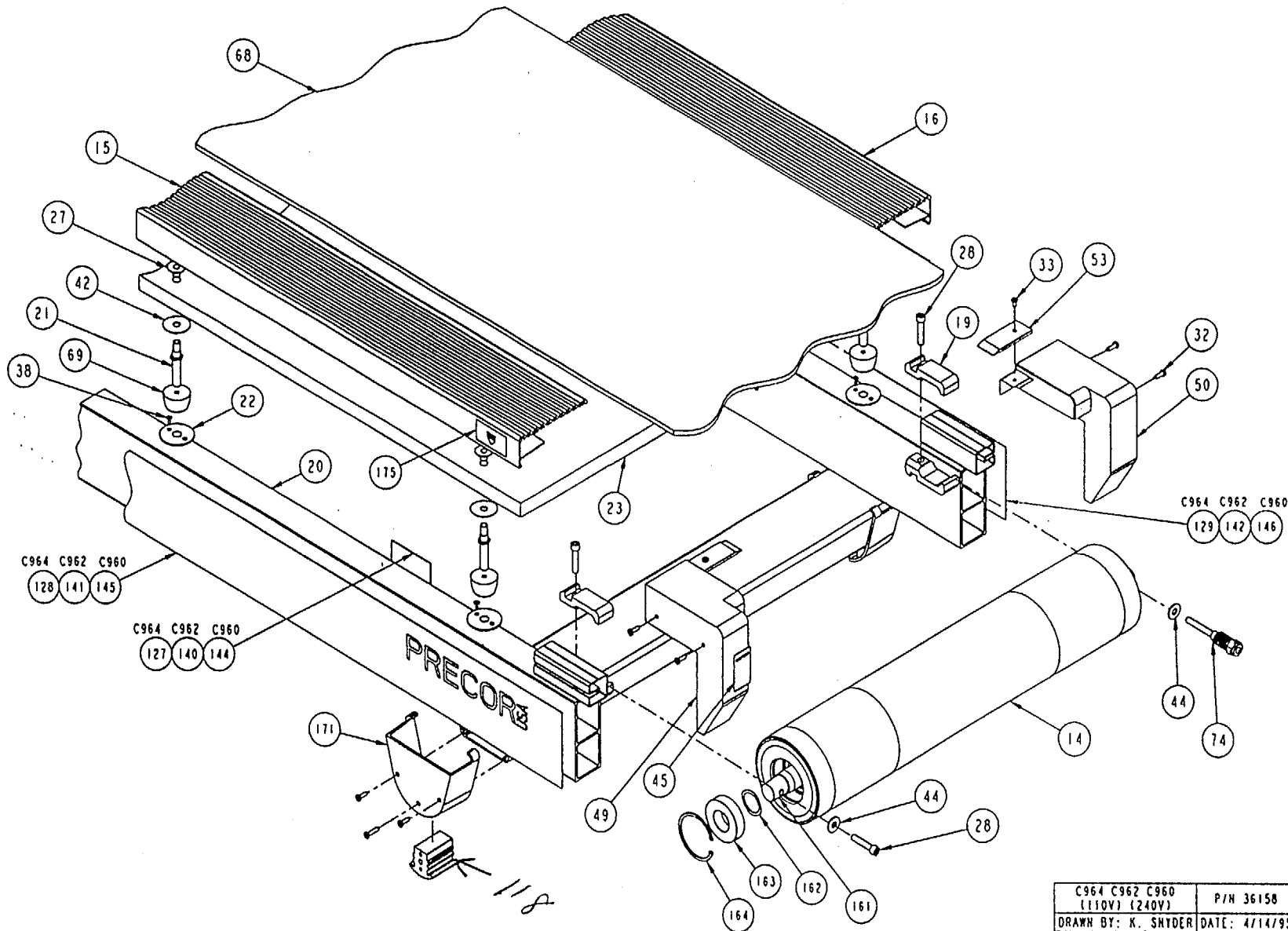

C964 C962 C960 (110V) (240V)	P/N 36158	REV: F
DRAWN BY: K. SHYDER	DATE: 4/14/95	SHEET 4 OF 5

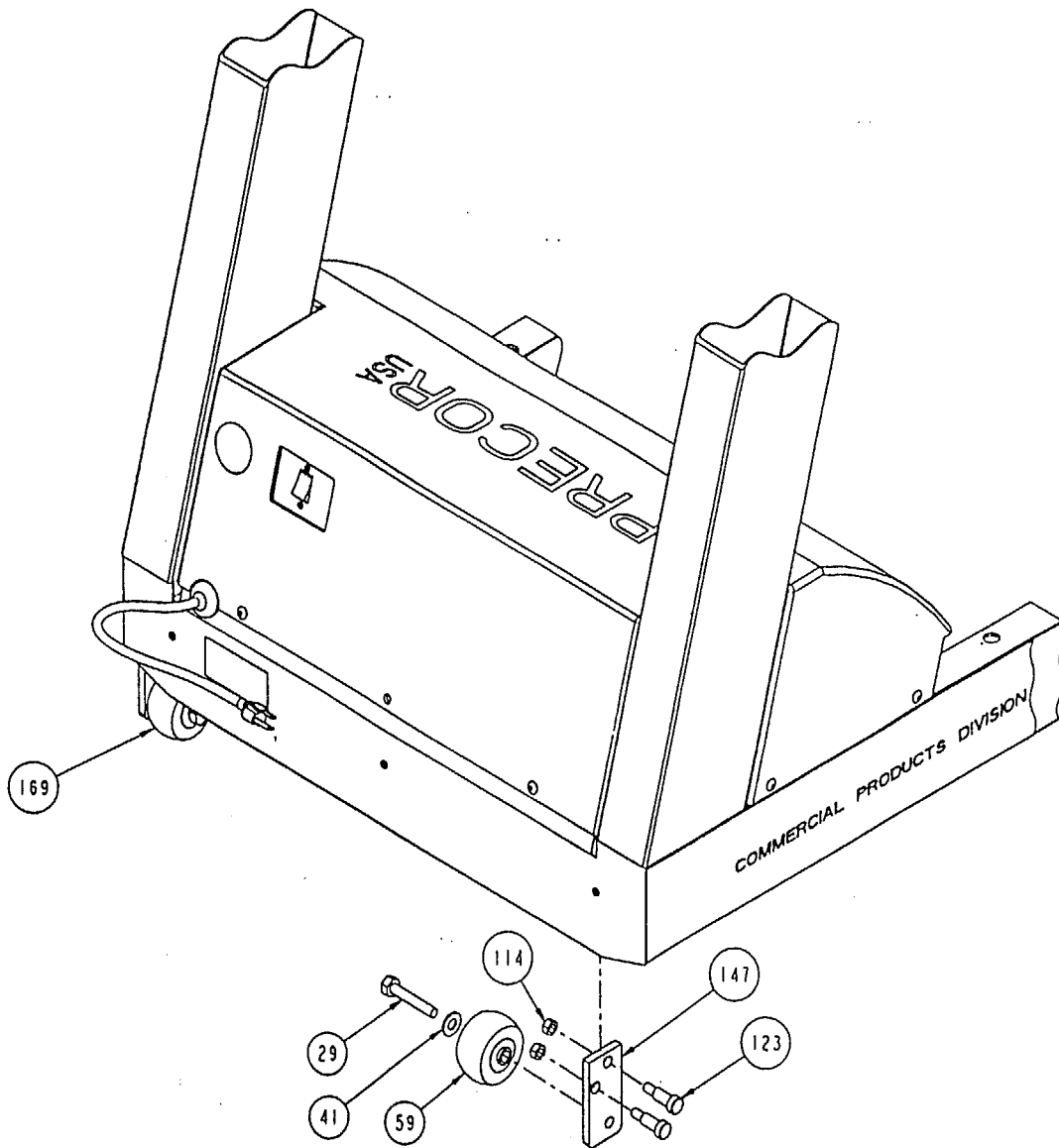

C960	P/N 36158	REV: F
(110V) (240V)	DATE: 4/14/95	SHEET 5 OF 5
DRAWN BY: K SNYDER		

**C962 (120 VAC, version 1) (serial code 80)**

<b>Part Number</b>	<b>Description</b>	<b>Bubble Number</b>
10766-101	XFORMER,120/220VAC,28VCT,3.6A	1
10857-110	DIODE BRIDGE/SCR MODEUL,42.5A	2
33432-106	ASSY, RIBBON CABLE	6
33868-105	ASSY, CABLE SPEED SENSOR,C960	9
33490-102	ASSY, TAKE-UP ROLLER, C960/SP	14
33560-102	ASSY, DRIVE ROLLER, C960/SP	17
38940-101	BRACKET,HALL EFFECT SENSOR	18
33572-104	MOUNT, ROLLER, 5/16-18 C960	19
33873-104	STUD, BED SPRING	21
36103-105	BUSHING,BED,C960	22
48401-102	BED, ASSEMBLED, BLACK C96XI	23
59001-102	ASSY,SAFETY CLIP	24
KGCN031-027	LOCKNUT,STARWASHER,5/16-18,1/2	25
KGCN016-013	LOCKNUT, STARWASHER 8-32, HEX	26
KANNN038-044	NUT, TEE, 3/8-16	27
CAKN031-150	SCREW,SKHD,5/16-18X1.50,BLK ZN,LK	28
HCKN050-250	SCREW,HEX,GR 5,1/2-13X2-1/2,BLK ZN	29
TAKN031-275	SCREW,BTHD,5/16-18X2-3/4,BLK ZN	30
TAKN019-063	SCREW,BTHD,10-24X5/8,BLK ZN	31
PBKN019-075	SCREW,S/T,#10X3/4,PANHD,PHIL,	32
PBKN019-050	SCREW,S/T,#10X1/2,PANHD,PHIL,	33
PGKN016-050	SCREW,S/T,#8X1/2,TRS,PHIL,BLK	34
MGCN016-063	SCREW,MCH,8-32X5/8,PANHD,PHIL,	35
MHCN019-038	SCREW,MCH,10-32X3/8,PANHD,PHIL	36
MGCE013-025	SCREW,MCH,6-32X1/4,PANHD,PHIL,	37
PPCN011-038	SCREW,S/T,#4X3/8,FLTHD,PHIL,	38
EMKN008-010	SCREW,SET,M8-1.25XM10,KNRLDCUP	39
WACN019-005	WASHER, FLT, #10X.500X.049,ZN	40
WBCN050-010	WASHER, FLT, 1/2, ID=.531,	41
WABCN044-006	WASHER, FEN. 7/16, ID=.500,	42
WATNN020-002	WASHER, LK-INT, #10, ID=.200,	43
WCCN031-008	WASHER, FLT, 5/16X.875X.083	44
33859-103	LABEL, SIDERAIL, FRONT, C960	46
10736-501	WASHER, RAIL, C960/SP,PT	48
33528-106	ENDCAP, RIGHT REAR, PT	49
33528-105	ENDCAP, LEFT REAR, PT C960	50
33644-104	WELDMENT, BASE PLATE, PAINTED,	51
33656-104	PLATE, FRONT BUMPER, PAINTED,	52
36400-103	GUARD, ETL COMPLIANCE	53
33735-201	WELDMENT, TARGA LEFT, PAINTED	54
33735-202	WELDMENT, TARGA RIGHT,PAINTED	55
33736-102	HANDRAIL, FRONT,PT	56
10123-102	CABLE TIE, 3-7/8 LONG,WHITE,NYL	57
10753-101	FAN,MOTOR HUB	61
59007-105	ASSY, HOOD & KEYLOC C960	63
33849-102	BRACKET, HOOD C960	64
10737-103	BELT, DRIVE, MOTOR, C960	65
36355-127	RUNNING BELT, SIEGLING, 138.10 X 20	68
33563-102	SPRING, BED SUPPORT	69

38756-101	ASSY, FLYWHEEL,964I	71
ACHN244-008	RING,RETAINER	74
10213-105	BUSHING,OILITE,5/8 OD X 1/2 ID	75
10035-108	CAP,AL-E,2200UF,200V,2.02 X3.69	76
10775-103	CAP,MOTOR RUN,25UF,370VAC	77
10036-101	CLAMP,CAPACITOR,2.0 NOM	78
10036-104	CLAMP,CAPACITOR,1.75 DIA	79
10479-101	CAPACITOR CAP,2 OD X 1 HIGH	80
10650-102	MAGNET,0.365 D X 0.25	81
10435-101	CKT BRKR,250V,MAGNETIC,ROCKER,	82
10741-101	SWITCH,LIMIT,	83
33573-102	MOTOR, 90V, C960/SP	85
33658-106	MOTOR,LIFT,120V,C94X ONLY	86
TAKN031-050	SCREW,BTHD,5/16-18X1/2,BLK ZN	88
KDCN011-008	LOCKNUT, FULL, 4-40,ZINC PLT	89
MGCE011-075	SCREW,MCH,4-40X3/4,PANHD,PHIL,	91
10731-101	SWITCH,MICRO,	93
59000-162	ASSY, HOUSING & KEYPAD W/O	94
33867-102	ASSY,CBL, UPPER- SAFETY	99
35615-103	ASSY,LINE CORD,125V,20 AMPS	105
37172-102	ASSY, CABLE, LIFT SENSOR	108
45499-020	ASSY,CBL,14 AWG,RING/QK DISC,BROWN,	109
45498-020	ASSY,CBL,14 AWG,RING/QK DISC,BLUE,2	110
44270-101	WHEEL, LIFT	111
36171-104	LABEL, WIRING DIAGRAM, C960,	113
KDCN038-025	LOCKNUT, FULL, 3/8-16, ZINC	114
CAKN025-038	SCREW,SKHD,1/4-20X3/8,BLK ZN,LK	115
CAKN013-050	SCREW,SKHD,6-32X0.50,BLK ZN,LK	116
36382-103	FOOT, C960	118
MGCN011-019	SCREW,MCH,4-40X3/16,PANHD,PHIL	119
RANE025-150	SCR,SHLD,1/4X20 X1-1/2 ,HEXSC	121
RCNN038-400	SCREW,SHLD,1/2 X 4 ,HEXSC,	122
RANN038-150	SCR,SHLD,1/2 X 1-1/2 ,HEXSC	123
RCNN038-325	SCR,SHLD,1/2 X 3-1/4 ,HEXSC,	124
EKKN025-025	SCREW,SET,1/4-20X1/4,KNRLDCUP,	125
WCCN025-007	WASHER, FLT, 1/4X.734X.065	126
59012-101	ASSY, LIFT PLATFORM, C960	132
33932-101	BLOCK, ACTUATOR	133
33702-101	BRACKET, SENSOR	134
33703-102	BRACKET, LIMIT SWITCH	135
37632-101	ACTUATOR, SWITCH	136
33934-104	SHAFT, ACTUATOR, FINISH C960	137
33663-115	PCA,DISPLAY,CLUB,C962I	138
33729-113	LABEL, DISPLAY ENGLISH C962	139
10872-103	IC,PROCESSOR,80C32,12MHZ,DIP40	147
WAGNN117-002	WASHER, WAVE, 1.50 OD X 1.17	162
10397-101	BEARING, ROLLER M TREAD	163
10133-124	RING,RETAINER	164
AAHN034-006	RING,RETAINER,3/4,EXT	166
36166-101	SHIELD, POWER C960	167
33272-101	LABEL, CAPACITOR DISCHARGE	168

10332-101	MOUNT, CABLE TIE	170
59006-101	ASSY, REAR FOOT C960	171
32062-101	LABEL, CAUTION, RISK OF FIRE	173
37621-101	LABEL,GROUND EFFECTS,OVAL,DURO-LENZ	175.01
WATNN025-003	WASHER, LK-INT, ID=.25,	176
KDKN025-023	LOCKNUT, FULL, 1/4-20, BLK ZN	177
WCKN025-007	WASHER, PLAIN 1/4 BLACK	178
PKCN019-075	SCREW,S/T,#10X.75,WSHHXHD,ZN	180
36402-103	ETL/FCC LABEL C960 SERIES	181
36450-103	SAFETY GUARD, ALUM, C960	182
CCKN025-075	SCREW,SKHD,1/4-20X0.75,BLK ZN,LK	184
WACPN028-003	WASHER,.281"ID,.500"OD,.031"	186
DCKN019-100	SCREW,WOOD #10X1, L=1.00	188
10237-102	LOCKNUT,1-19/64 X 9/32 ,NYLON	189
WATNN012-002	WASHER, LK-INT, #4, ID=.119	192
38876-501	GASKET,RUBBER,HALL EFFECT	193
WACN019-005	WASHER, FLT, #10X.500X.049,ZN	195
33666-103	ASSY, ELEC.MODULE,LOWER, M9.43, M9.	201
59002-102	ASSY,SHIPPER,C960	209
10427-140	FUSE,SLOW,2A,250V,1/4 DIA	212
34065-101	INSTRUCTIONS, HANDRAIL OPTION	215
35628-102	HANDRAIL, SHORT, PAINTED	216
35629-102	HANDRAIL, LONG, PAINTED	217
10123-101	CABLE TIE,11 LONG,WHITE,NYL	218
33881-101	SHIPPER, FOAM, 180 EA/ROLL	219
36192-101	BUSHING, SPANNER	220
10123-103	CABLE TIE, 36 LONG,WHITE,NYLON	224
20038-101	SPRING, MOTOR BRUSH, 3 HP	226
59008-101	KIT, LIFT REVOLUTION SENSOR	228
59011-105	ASSY, SPEED SENSOR, 120V LARGE	229
10427-115	FUSE,SLOW,.50A,250V,1/4 DIA	230
10427-140	FUSE,SLOW,2A,250V,1/4 DIA	231
11085-105	FUSE,FAST,5A,300V,W/HOLDER	231
20029-102	BELT, DRIVE, LIFT, DAYCO	232
59005-102	ASSY, WELDMENT FRAME & LABOR	235
20002-106	BRUSH, MOTOR, PAC SCI, C960	990
33523-105	KIT, LITERATURE, C960 & C962	999